

manual

MOUNTING – DISMOUNTING

ASSEMBLING – DISASSEMBLING
INSTRUCTION

TECHNICAL INFORMATION

ET-W D
ET-W DB
ET-W B



SAFETY AND QUALITY

Health and safety

Incorrect assembly/installation may damage the keg spear and poses the risk that components may occasionally come off during initial pressurization and can cause harm to product and person.

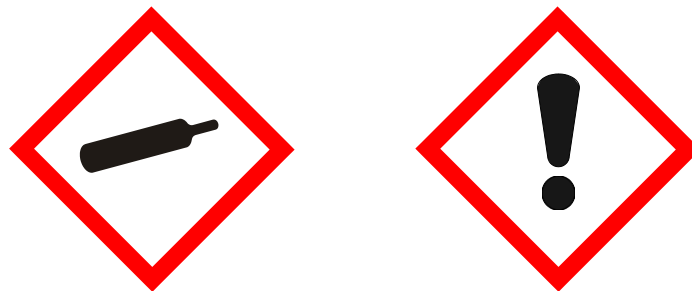

Quality

Specialised sealing systems made of high-grade materials are in daily utilisation with all our types of extractor tubes. Due to continuous improvement of our technology, we are able to equip all S-type and D-type systems with a five-year warranty.

LIST OF CONTENTS

1. Mounting Instruction
2. Dismounting Instruction ET-W D
3. Dismounting Instruction ET-W DB / ET-W B
4. Disassembling Instruction
5. Assembling Instruction
6. Tool List
7. Technical Information
8. Connections

MOUNTING INSTRUCTION

EXTRACTOR TUBE ET-W D / ET-W DB / ET-W B

1. Mounting Instruction

ET-W D



ET-W DB



ET-W B



MOUNTING INSTRUCTION

EXTRACTOR TUBE ET-W D / ET-W DB / ET-W B

Fig. 01



1. Moisten the extractor tube with water.

Fig. 02



2. Check the keg neck is clean. Clean the keg neck from any contaminations.

Fig. 03



3. Check the sealing ring is not damaged and is positioned correctly.

MOUNTING INSTRUCTION

EXTRACTOR TUBE ET-W D / ET-W DB / ET-W B

Fig. 04



4. Check if lock/safety is O.K. Insert the extractor tube straight.

Fig. 05



5. Turn the extractor tube clockwise until it engages in the socket.

Fig. 06



6. Place the ring segment of the DSI assembly tool around the drum sleeve. Place the retaining ring on the pressure piece of the assembly tool as shown. Align the slots of the pressure piece of the assembly tool with the cams of the extractor tube housing by turning the entire tool.

MOUNTING INSTRUCTION

EXTRACTOR TUBE ET-W D / ET-W DB / ET-W B

Fig. 07



7. Press the extractor tube into the barrel sleeve by turning the handles of the assembly tools to a horizontal position.

Fig. 08

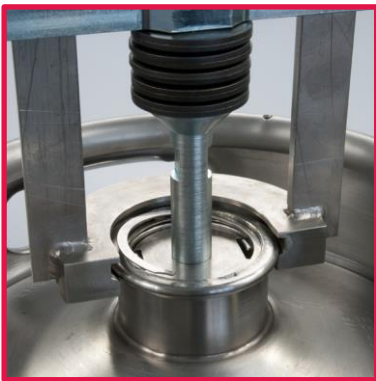

8. Insert the retaining ring into the groove of the drum sleeve. Make sure that the ring is fully retracted.

Fig. 09



9. Remove the screw-in/screw-out tool. The keg is ready for use now.

DISMOUNTING INSTRUCTION

EXTRACTOR TUBE ET-W D

2. Dismounting Instruction ET-W D

ET-W D



ET-W DB



ET-W B



DISMOUNTING INSTRUCTION

EXTRACTOR TUBE ET-W D

Fig. 10



1. Decompress the keg, e.g. by means of the DSI decompression and removal Tool.

Fig. 11



2. Place the ring segment of the DSI assembly tool around the barrel sleeve. Align the slots of the pressure piece of the assembly tool with the cams of the body by turning the complete tool.

Fig. 12

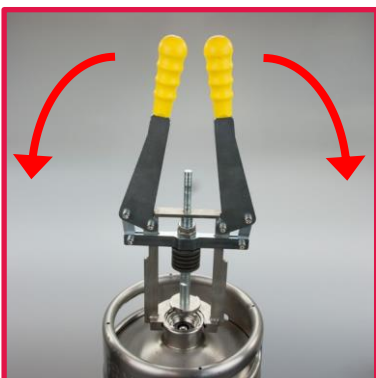

3. Press the extractor tube into the barrel sleeve by bringing the handles of the assembly tool into a horizontal position.

DISMOUNTING INSTRUCTION

EXTRACTOR TUBE ET-W D

Fig. 13

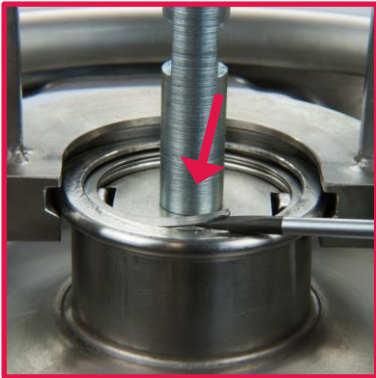

4. Use the DSI retaining ring remover to remove the ring from the groove of the drum sleeve. First remove the last coil and then the retaining ring from the groove. Turn the handles of the assembly tool to a vertical position and then remove the tool.

Fig. 14



5. Remove the extractor tube from the keg by turning it anti-clockwise and lift it up.

DO NOT USE THE RETAINING RING AGAIN!

DISMOUNTING INSTRUCTION

EXTRACTOR TUBE ET-W DB/ ET-W B

3. Disassembling instruction

ET-W D



ET-W DB



ET-W B



DISMOUNTING INSTRUCTION

EXTRACTOR TUBE ET-W DB / ET-W B

Fig. 15



1. Decompress the keg, e.g. by means of the DSI decompression and removal Tool.

Fig. 16

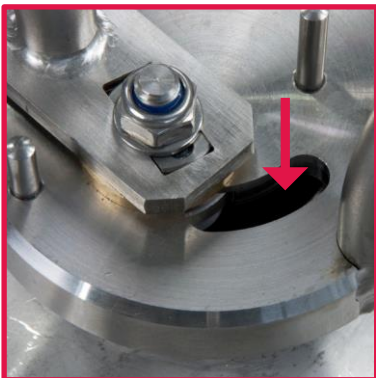

2. Place the tool for retaining ring removal flat on the drum sleeve with the handles open (against the retaining pin). Turn the tool until the opening of the circlip is visible through the curved slot. (see Fig. 09)

Fig. 17



3. Close the handles up to the retaining pin. The right-hand side of the retaining ring rises. With the handles closed, turn the entire tool approximately 270° clockwise until the circlip comes out of the barrel sleeve.

DISMOUNTING INSTRUCTION

EXTRACTOR TUBE ET-W DB/ ET-W B

Fig. 18



4. Open the handles (up to the retaining pin).
Remove the tool from the barrel sleeve.

Fig. 19



5. Remove the extractor tube from the keg by turning it clockwise and lift it up.

DO NOT USE THE RETAINING RING AGAIN!

DISASSEMBLING INSTRUCTION

EXTRACTOR TUBE ET-W D / ET-W DB / ET-W B

4. Disassembling instruction

ET-W D



ET-W DB



ET-W B



DISASSEMBLING INSTRUCTION

EXTRACTOR TUBE ET-W D / ET-W DB / ET-W B

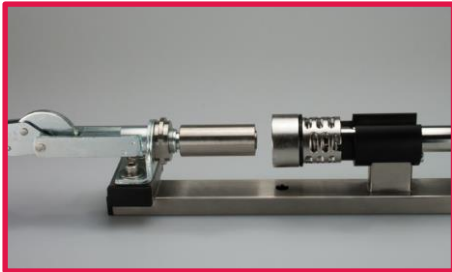

1. Put the extractor tube in the tool. Make sure that the three pins of the tool fit into the three holes in the bottom of the extractor tube.

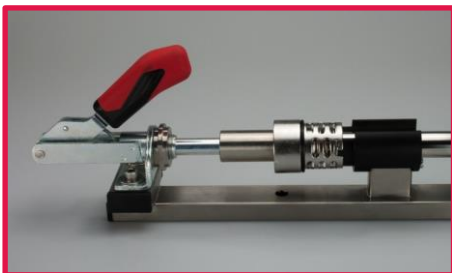

2. Pull the handle forward to compress the spring. Push the safety latch slightly inwards. Pull the body downward and turn it anti-clockwise until it is unlocked.



3. Move the body upwards and connect it to the tool by turning the body 90°.

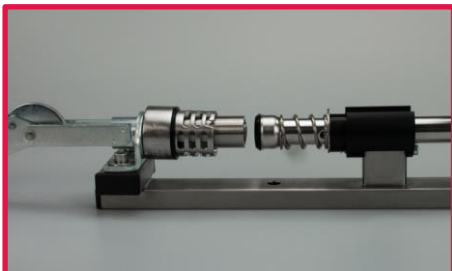

4. Push the handle backward. Take the subassembly out. Take the body off.



5. Take off the remaining parts. The extractor tube is disassembled.

DISASSEMBLING INSTRUCTION

EXTRACTOR TUBE ET-W D / ET-W DB / ET-W B

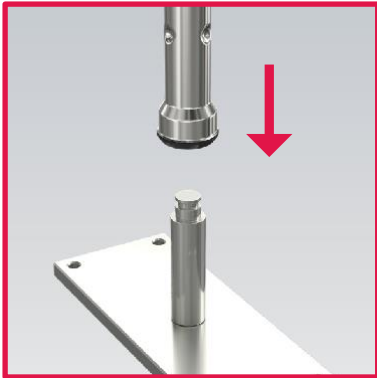

1. Press the tube with the seal onto the disassembling tool and press the ball inwards.



2. Pull the tube in a lateral direction until the seal is released from the tube.

The seal must be replaced after this process!



3. The ball and spring can now be removed from the tube.

ASSEMBLING INSTRUCTION

EXTRACTOR TUBE ET-W D / ET-W DB / ET-W B

5. Assembling instruction

ET-W D



ET-W DB



ET-W B



ASSEMBLING INSTRUCTION

EXTRACTOR TUBE ET-W D / ET-W DB / ET-W B



1. Replace the sealing ring on the body and the main seal. Assemble all parts.



2. Connect the body to the Assembling Tool. Put the subassembly in the Tool. Push the safety latch slightly inwards.

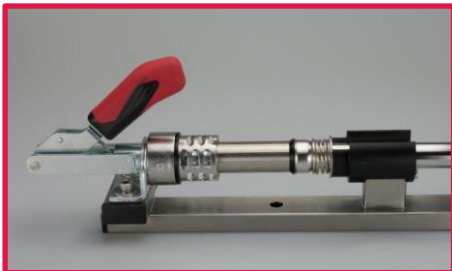

3. Pull the handle forward to compress the spring.



4. Pull the body downwards and turn it clockwise until it is locked to the Extractor Tube Plate. Make sure that the safety latch sticks through the big opening in the body.



5. Push the handle backward in order to tension the spring and take out the extractor tube. Please check the correct positions of the seals and the safety latch.

TOOLS

EXTRACTOR TUBE ET-W D / ET-W DB / ET-W B

6. Tool List

ET-W D



ET-W DB



ET-W B



TOOLS

EXTRACTOR TUBE ET-W D / ET-W DB / ET-W B



1. Decompression tool:

ET-W DB: part number: 910570

ET-W B: part number: 910570

ET-W D: part number: 910570



2. Tool for retaining ring removal:

ET-W DB: part number 910546

ET-W B: part number: 910546



3. Assembling/Disassembling tool:

ET-W DB: part number: 910544

ET-W B: part number: 910544

ET-W D: part number: 910544

TOOLS

EXTRACTOR TUBE ET-W D / ET-W DB / ET-W B



5. Disassembling tool:

ET-W DB: part number: 910548

ET-W B: part number: 910548

ET-W D: part number: 910547



6. Tool for retaining ring removal (Standard screwdriver):

ET-W D: part number: 027468.1

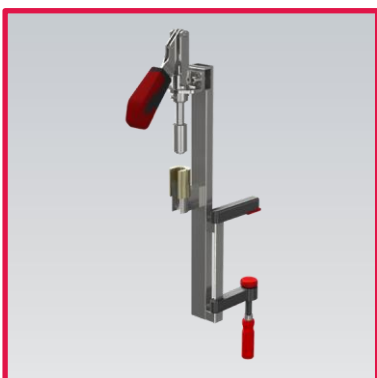

7. Assembling/Disassembling tool:

ET-W DB: part number: 910551

ET-W B: part number: 910549

ET-W D: part number: 910551

TOOLS

EXTRACTOR TUBE ET-W D / ET-W DB / ET-W B

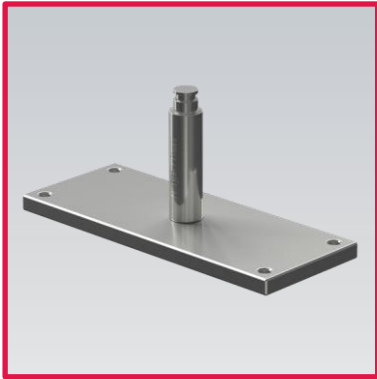

8. Disassembling tool CO₂ gasket :

part number: 910610



9. Assembling tool:

part number: 611899

TECHNICAL INFORMATION

EXTRACTOR TUBE ET-W D / ET-W DB / ET-W B

7. Technical Information

ET-W D



ET-W DB



ET-W B



TECHNICAL INFORMATION

EXTRACTOR TUBE ET-W D

Product Information	Produktinformationen	Stroke and Passages	open Position	while Cleaning / Filling	Hub und Öffnungsquerschnitte	offene Position	während Reinigung / Befüllen
according to DIN 6650 and FDA regulations	Produkt nach DIN 6650 und FDA Bestimmungen	CO ₂ valve + tube part 9 + part 1 – part 7	A 3 mm	4-6 mm	CO ₂ -Dichtung + Steigrohr Pos. 9 + Pos. 1 – Pos. 7	A 3 mm	4-6 mm
gesight	gesicht	ball part 2 – part 9	B 4 mm	6,5-8 mm	Kugel Pos. 2 – Pos. 9	B 4 mm	6,5-8 mm
For specific length calculation keg drawing or H3-dimension is needed according to DIN 6647	Für konkrete Längenberechnung wird die Keg-Zeichnung oder das H3-Maß nach DIN 6647 benötigt	inside the seal part 9	C	250 mm ²	innerhalb der Dichtung Pos. 9	C	250 mm ²
mounting torque -	Anzugsdrehmoment -	through inner tube part 2 – part 1	D	160-200 mm ²	innerhalb des Steigrohres Pos. 2 – Pos. 1	D	280 mm ² 160-200 mm ²
temperature resistance short-time 160°C	Temperaturbeständigkeit kurzfristig 160°C	through inner tube Ø23.6 part 1	E	440 mm ²	innerhalb des Steigrohres Ø23.6 Pos. 1	E	440 mm ²
for more information www.dsiensgroup.com	Für mehr Informationen www.dsiensgroup.com	through outer tube part 7 – part 9	F	330 mm ²	außerhalb des Steigrohres Pos. 7 – Pos. 9	F	330 mm ²
		in part 7	G	1660 mm ²	in Pos. 7	G	1660 mm ²

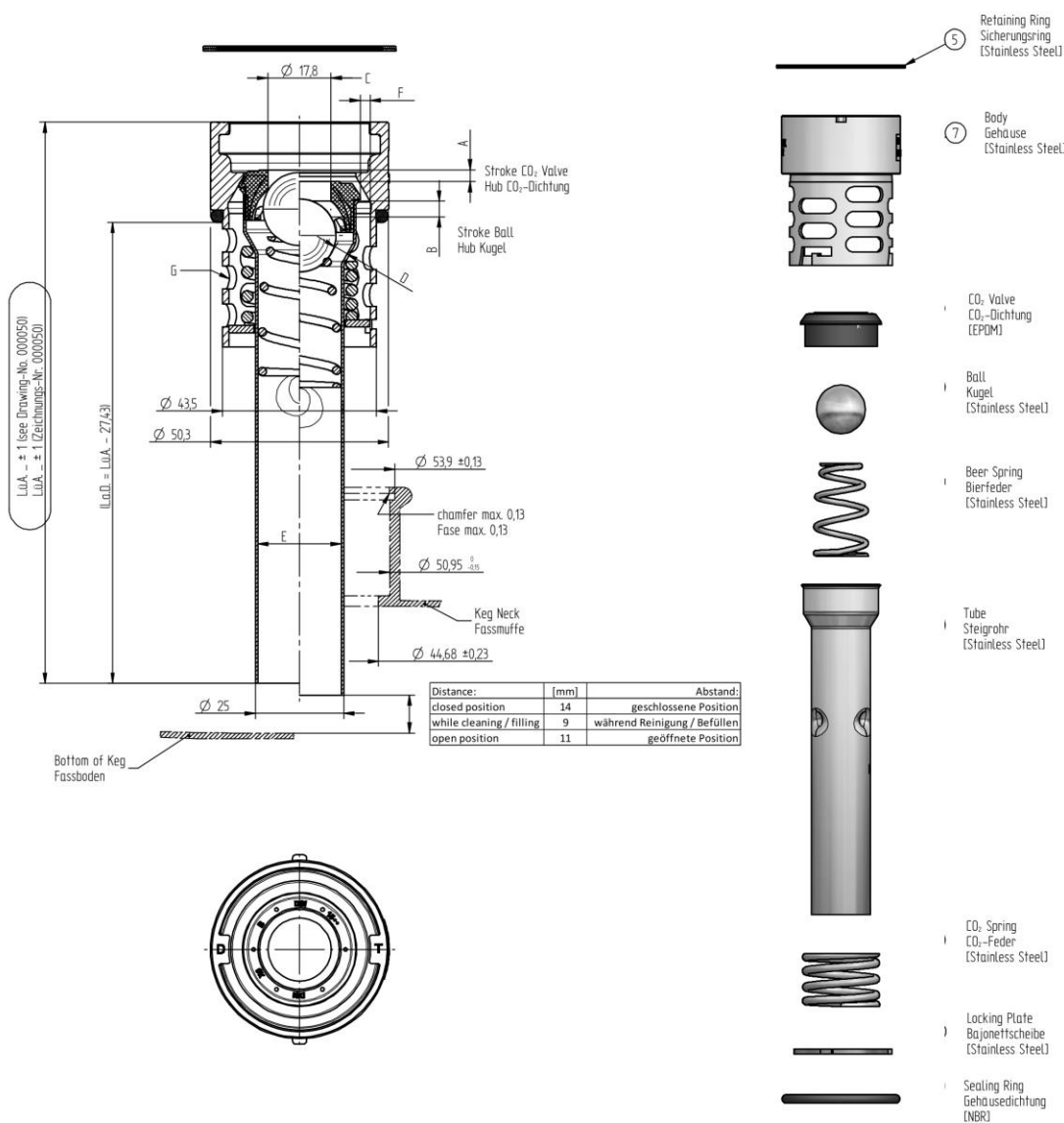

weight calculation ± 5% / Gewichts Berechnung ± 5%

$$m [g] = (L \cdot \bar{u} \cdot A \cdot [\text{mm}] - 40) \cdot 0,419 \frac{g}{\text{mm}} + 300g$$

Pos.	Quantity	Art.-No.	Title
1	1	000041	Down Tube WD
2	1	0267036	Ball
3	1	026705.8	CO ₂ Spring
4	1	026708.0	O-Ring 40,87 x 3,53
5	1	026709.1	Retaining Ring
6	1	554352.7	Locking Plate
7	1	610342	Body WD
8	1	611056	Beer Spring
9	1	611060	CO ₂ Valve WD Blow-Off

PRODUCT		TOLERANCES	LAST CHANGE	SCALE: 1:1 (1:25)	WEIGHT VOLUME
WD Standard - Blow Off		(IN Ø) (F) (H) (K) (L) (M) (N) (P) (R) (S) (T) (U) (V) (W) (X) (Y) (Z) (AS) (BS) (CS) (DS) (ES) (FS) (GS) (HS) (JS) (KS) (MS) (NS) (PS) (QS) (RS) (TS) (US) (VS) (WS) (XS) (YS) (ZS)	- X Δ		
		ROUGHNESS			
		RENDER			
		DATE	10.04.2015		
		BY	issako		
		NO	3024		
		DATE	12.03.2020		
		BY	kunze		
		NO	3028		
		DATE	11.07.2023		
		BY	kunze		
		NO	3029		
		DATE	12.03.2020		
		BY	kunze		
		NO	3029		
		DATE	11.07.2023		
		BY	kunze		
		NO	3029		
		DATE	11.07.2023		
		BY	kunze		
		NO	3029		
		DATE	11.07.2023		
		BY	kunze		
		NO	3029		
		DATE	11.07.2023		
		BY	kunze		
		NO	3029		
		DATE	11.07.2023		
		BY	kunze		
		NO	3029		
		DATE	11.07.2023		
		BY	kunze		
		NO	3029		

This drawing is the property of Dispenze Systems International. The information on it is confidential and must not be copied for any other purpose without the prior written permission of DSI (Dispenze Systems International GmbH). If in doubt, please ask. Samples are required after each revision.

TECHNICAL INFORMATION

EXTRACTOR TUBE ET-W DB

EN	DE	EN		DE	
Product Information	Produktinformationen	Stroke and Passages	open Position	Hub und Öffnungsquerschnitte	ohne Passtime
according to DIN 6650 and FDA regulations	Produkt nach DIN 6650 und FDA Bestimmungen	I	A	CO ₂ -Dichtung + Steigrohr Pos. 8 + Pos. 1 - Pos. 4	A
gaslight	Gasdicht			4-6 mm	
for specific Length calculation keg drawing or H3-dimension is needed according to DIN 6647	Für konkrete Längenberechnung wird die Keg-Zeichnung oder das H3-Maß nach DIN 6647 benötigt	II	B	ball part 9 - part 8	B
mounting torque -	Anzugsdrehmoment -			6,5-8 mm	
temperature resistance short-time 160°C	Temperaturbeständigkeit kurzfristig 160°C	III	C	inside the seal part 8	C
for more information www.dispensegroup.com	für mehr Informationen www.dispensegroup.com			250 mm²	
			D	through inner tube part 9 - part 1	D
			E	through inner tube Ø23.6 part 1	E
			F	through outer tube part 4 - part 8	F
			G	in part 4	G

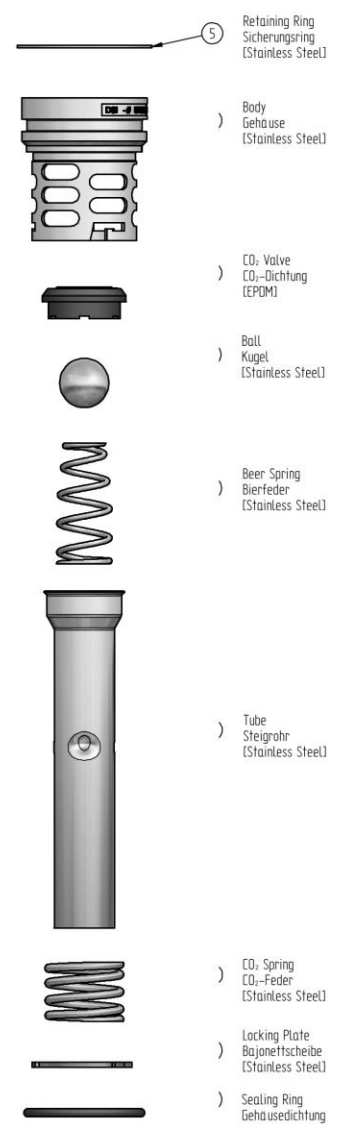
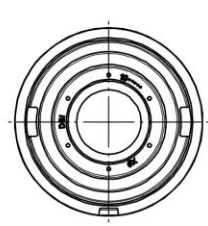
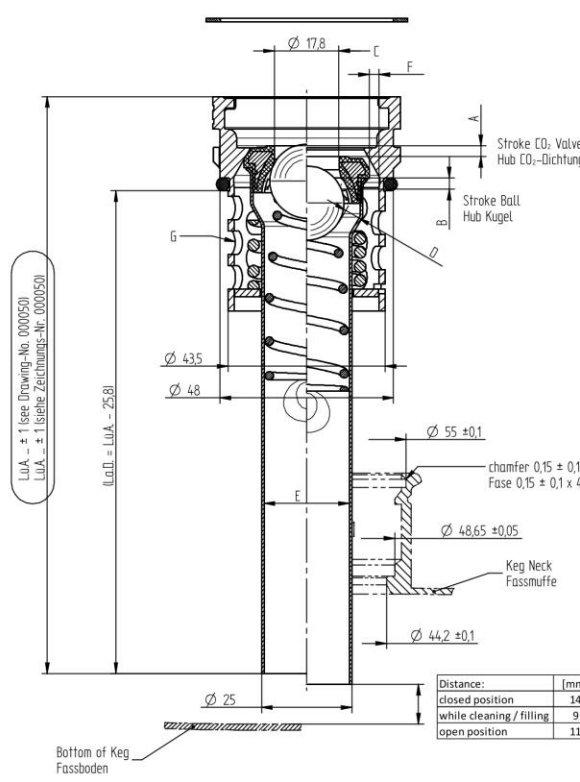

weight calculation ± 5% / Gewichtsrechnung ± 5%

$$m [g] = (L. \dot{u}. A. [mm] - 40) * 0,419 \frac{g}{mm} + 290g$$

Pos.	Quantity	Art.-No.	Title
1	1	000047	Down Tube CUB
2	1	026705.8	Spring CO ₂
3	1	026708.0	O-Ring 40,87 x 3,53
4	1	026842.2	Body WB
5	1	026993.1	Retaining Ring
6	1	554352.7	Locking Plate
7	1	610488	Valve Spring
8	1	610504	CO ₂ Valve WD
9	1	611186	Ball

This drawing is the property of Dispace Systems International. The information on it is confidential and must not be copied for any other purpose without the prior written permission of DSI. In the event of a change, the latest revision shall be used. If in doubt, please ask. Samples are required after each revision.

PRODUCT Ozeanien	TOLERANCES UNLESS OTHERWISE SPECIFIED FRACTIONS 1/16 1/8 1/4 1/2 3/4 1 1 1/4 1 1/2 2 2 1/2 3 3 1/2 4 4 1/2 5 5 1/2 6 6 1/2 7 7 1/2 8 8 1/2 9 9 1/2 10 10 1/2 11 11 1/2 12 12 1/2 14 14 1/2 16 16 1/2 18 18 1/2 20 20 1/2 22 22 1/2 24 24 1/2 26 26 1/2 28 28 1/2 30 30 1/2 32 32 1/2 34 34 1/2 36 36 1/2 38 38 1/2 40 40 1/2 45 45 1/2 50 50 1/2 55 55 1/2 60 60 1/2 65 65 1/2 70 70 1/2 75 75 1/2 80 80 1/2 85 85 1/2 90 90 1/2 95 95 1/2 100 100 1/2 105 105 1/2 110 110 1/2 115 115 1/2 120 120 1/2 125 125 1/2 130 130 1/2 135 135 1/2 140 140 1/2 145 145 1/2 150 150 1/2 155 155 1/2 160 160 1/2 165 165 1/2 170 170 1/2 175 175 1/2 180 180 1/2 185 185 1/2 190 190 1/2 195 195 1/2 200 200 1/2 205 205 1/2 210 210 1/2 215 215 1/2 220 220 1/2 225 225 1/2 230 230 1/2 235 235 1/2 240 240 1/2 245 245 1/2 250 250 1/2 255 255 1/2 260 260 1/2 265 265 1/2 270 270 1/2 275 275 1/2 280 280 1/2 285 285 1/2 290 290 1/2 295 295 1/2 300 300 1/2 305 305 1/2 310 310 1/2 315 315 1/2 320 320 1/2 325 325 1/2 330 330 1/2 335 335 1/2 340 340 1/2 345 345 1/2 350 350 1/2 355 355 1/2 360 360 1/2 365 365 1/2 370 370 1/2 375 375 1/2 380 380 1/2 385 385 1/2 390 390 1/2 395 395 1/2 400 400 1/2 405 405 1/2 410 410 1/2 415 415 1/2 420 420 1/2 425 425 1/2 430 430 1/2 435 435 1/2 440 440 1/2 445 445 1/2 450 450 1/2 455 455 1/2 460 460 1/2 465 465 1/2 470 470 1/2 475 475 1/2 480 480 1/2 485 485 1/2 490 490 1/2 495 495 1/2 500 500 1/2 505 505 1/2 510 510 1/2 515 515 1/2 520 520 1/2 525 525 1/2 530 530 1/2 535 535 1/2 540 540 1/2 545 545 1/2 550 550 1/2 555 555 1/2 560 560 1/2 565 565 1/2 570 570 1/2 575 575 1/2 580 580 1/2 585 585 1/2 590 590 1/2 595 595 1/2 600 600 1/2 605 605 1/2 610 610 1/2 615 615 1/2 620 620 1/2 625 625 1/2 630 630 1/2 635 635 1/2 640 640 1/2 645 645 1/2 650 650 1/2 655 655 1/2 660 660 1/2 665 665 1/2 670 670 1/2 675 675 1/2 680 680 1/2 685 685 1/2 690 690 1/2 695 695 1/2 700 700 1/2 705 705 1/2 710 710 1/2 715 715 1/2 720 720 1/2 725 725 1/2 730 730 1/2 735 735 1/2 740 740 1/2 745 745 1/2 750 750 1/2 755 755 1/2 760 760 1/2 765 765 1/2 770 770 1/2 775 775 1/2 780 780 1/2 785 785 1/2 790 790 1/2 795 795 1/2 800 800 1/2 805 805 1/2 810 810 1/2 815 815 1/2 820 820 1/2 825 825 1/2 830 830 1/2 835 835 1/2 840 840 1/2 845 845 1/2 850 850 1/2 855 855 1/2 860 860 1/2 865 865 1/2 870 870 1/2 875 875 1/2 880 880 1/2 885 885 1/2 890 890 1/2 895 895 1/2 900 900 1/2 905 905 1/2 910 910 1/2 915 915 1/2 920 920 1/2 925 925 1/2 930 930 1/2 935 935 1/2 940 940 1/2 945 945 1/2 950 950 1/2 955 955 1/2 960 960 1/2 965 965 1/2 970 970 1/2 975 975 1/2 980 980 1/2 985 985 1/2 990 990 1/2 995 995 1/2 1000 1000 1/2	LAST CHANGE MATERIAL SCALE: 1:21 (1:25) WEIGHT VOLUME
DESKIN 13.04.2015 AW 3024 12.03.2020 05.09.2016	DATE: 13.04.2015 DRAWN: 12.03.2020 DATE: 05.09.2016	TITLE: Master Extractor Tube W DB
PROJ. NO.: 1000049 A2	DATE: 13.04.2015 DRAWN: 12.03.2020 DATE: 05.09.2016	REV.:

TECHNICAL INFORMATION

EXTRACTOR TUBE ET-W B

EN	DE	EN	open Position	white Cleaning/ Filling	DE	offene Position	während Reinigung/ Befüllen		
Product Information	Produktinformationen	Stroke and Passages			Hub und Öffnungsquerschnitte				
according to DIN 6650 and FDA regulations	Produkt nach DIN 6650 und FDA Bestimmungen	I CO ₂ valve + tube part 4 + part 1 - part 6	A	3mm	4-6 mm	CO ₂ Dichtung + Steigrohr Pos. 4 + Pos. 1 - Pos. 6	A	3mm	4-6 mm
gaslight	gasdicht	beer clip part 2 - part 4	B	4 mm	6,5-8 mm	Bierklipp Pos. 2 - Pos. 4	B	4 mm	6,5-8 mm
for specific length calculation keg drawing or H3-dimension is needed according to DIN 6647	Für konkrete Längenberechnung wird die Keg-Zeichnung oder das H3-Maß nach DIN 6647 benötigt	through the CO ₂ valve part 4	C		160 mm ²	innerhalb der CO ₂ -Dichtung Pos. 4	C		160 mm ²
mounting torque -	Anzugsdrehmoment -	through inner tube part 2 - part 1	D		125 mm ²	innerhalb des Steigrohres Pos. 2 - Pos. 1	D		125 mm ²
temperature resistance short-time 135°C	Temperaturbeständigkeit kurzfristig 135°C	through inner tube Ø17,6 part 1	E		240 mm ²	innerhalb des Steigrohres Ø17,6 Pos. 1	E		240 mm ²
for more information www.dispensegroup.com	für mehr Informationen www.dispensegroup.com	through outer tube part 6 - part 4	F		240 mm ²	außerhalb des Steigrohres Pos. 6 - Pos. 4	F		240 mm ²
		in part 6	G		1660 mm ²	in Pos. 6	G		1660 mm ²

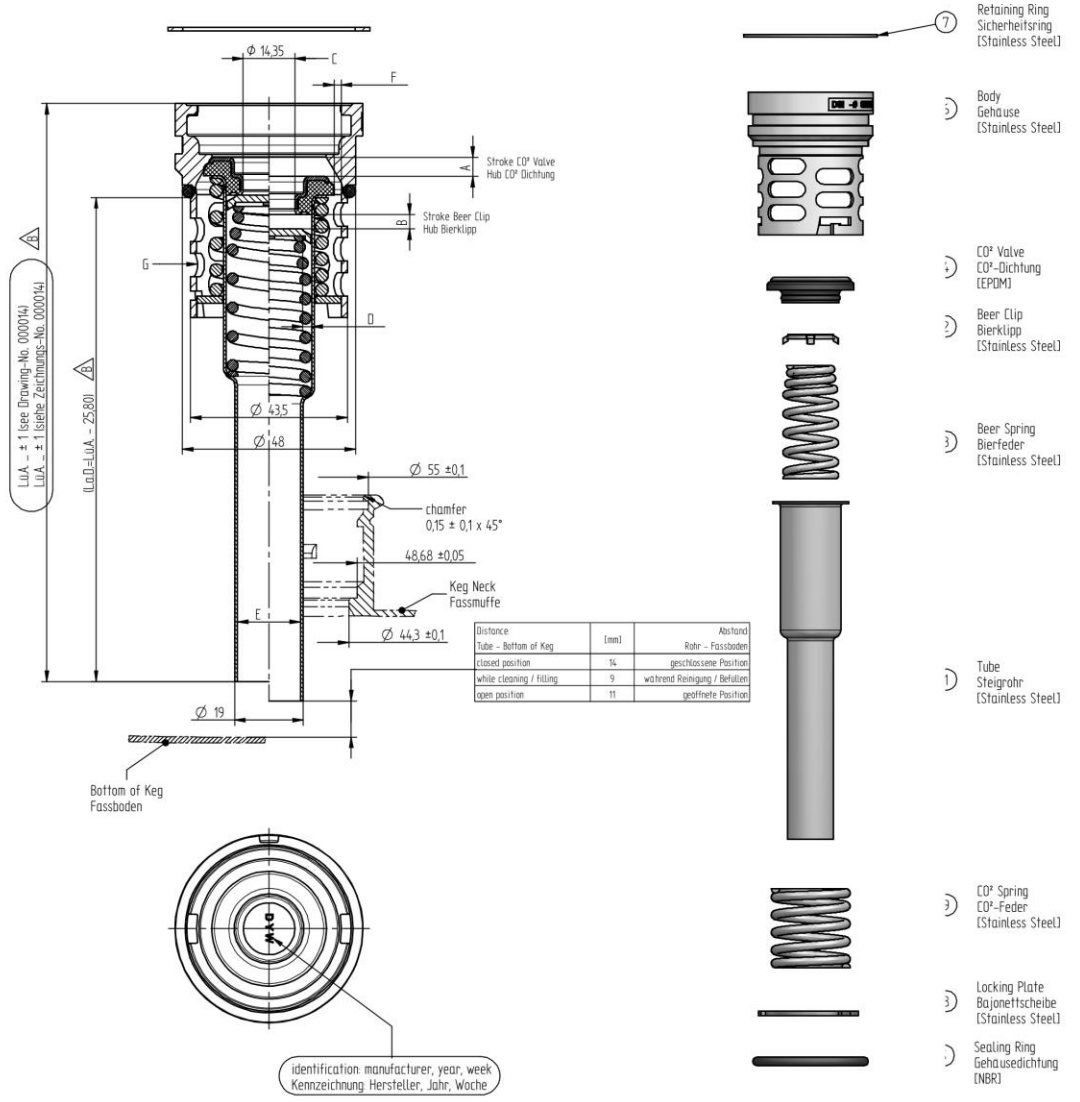

Pos.	Quantity	Art.-No.	Title
1	1	000037	Master Down Tube S Lange Tulpe
2	1	0262372	Beer Valve
3	1	0262383	Beer Spring
4	1	0266926	CO ₂ Valve Assy
5	1	026708.0	O-Ring 40,87 x 3,53
6	1	0268422	Body WB
7	1	0269931	Retaining Ring
8	1	554352.7	Locking Plate
9	1	555226.1	CO Spring

weight calculation ± 5% / Gewichtsberechnung ± 5%

$$m [g] = (L. \ddot{u}. A. [mm] - 80) \cdot 0,315 \frac{g}{mm} + 285g$$

PRODUCT	REMARKS	LAST CHANGE	SCALE	WEIGHT
	PROBINGNESS	2 x Δ	15 : 1 (1 : 125 : 1)	VOLUME
	DATE	DATE	TITLE	
	10.03.2015	18.07.2016	Master Extractor Tube W B	
	3024	28.07.2016		
	28.07.2016	28.07.2016		
DRAWING NUMBER				SHEET
A2				1
000039				1

DSI Getränkeanlagen GmbH.
 The information is confidential and should not be copied for any other purpose without the prior written permission of DSI.
 Die Informationen sind vertraulich und dürfen ohne schriftliche Genehmigung von DSI nicht weitergegeben werden.

CONNECTIONS

EXTRACTOR TUBE ET-W D / ET-W DB / ET-W B

8. Connections

ET-W-D



ET-W-DB



ET-W-B



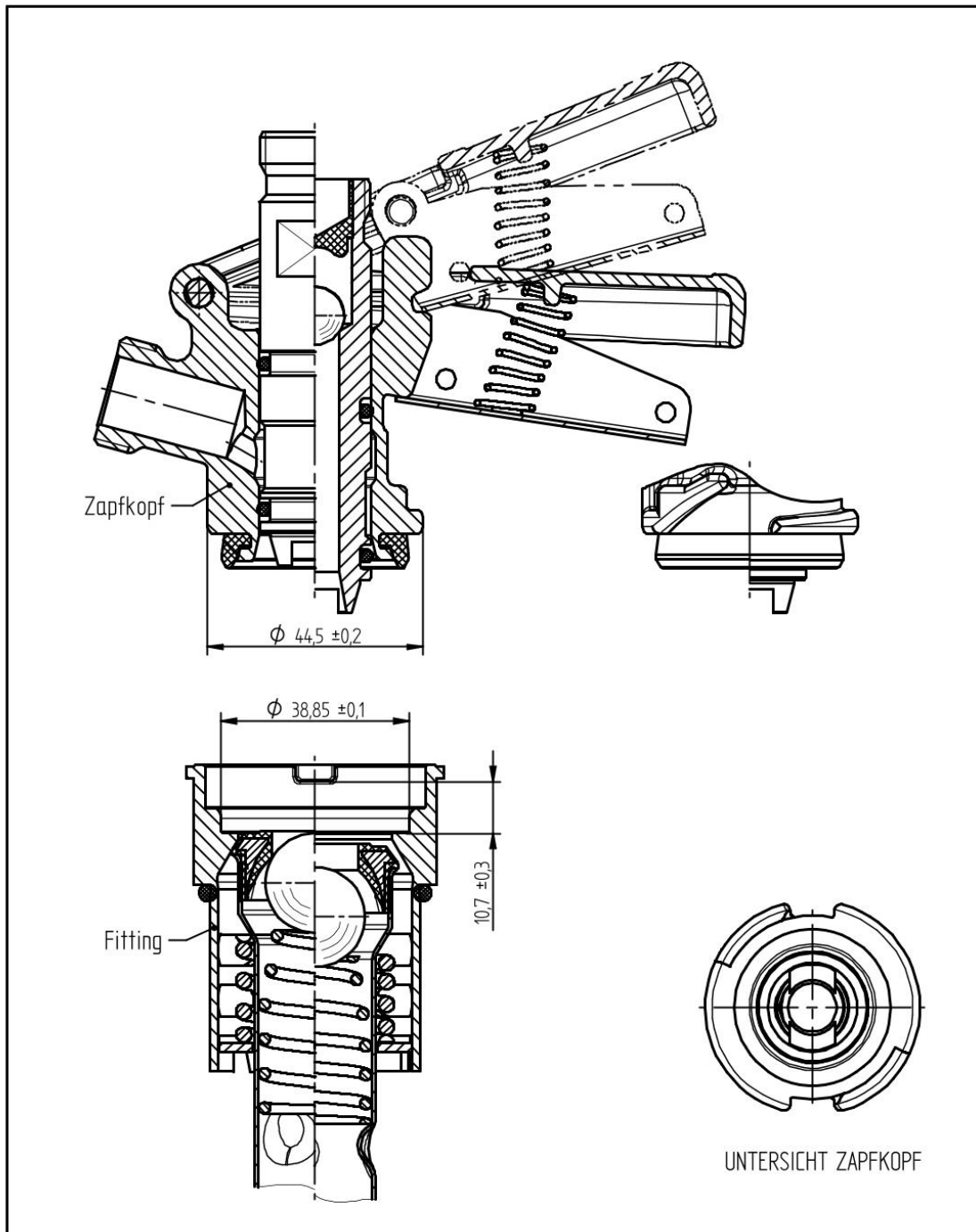

CONNECTIONS

EXTRACTOR TUBE ET-W D / ET-W DB



This drawing is the property of Dispense Systems International. The information on it is confidential, and must not be copied for any other purpose without the prior written permission of DSI Getränkearmaturen GmbH. If in doubt, please ask. Samples are required after each revision.

PRODUCT		TOLERANCES DIN ISO 2768-mH		LAST CHANGE		SCALE		WEIGHT VOLUME	
		ROUGHNESS DIN EN ISO 1302		- X Δ		MATERIAL			
		EDGES DIN EN ISO 13715		DATE		TITLE			
				DESIGN 17.11.2005 AH		Draft-Typ Verbindungssystem			
				AM 4427					
				2D 24.03.2020 kunze		FILE NAME: ET W D bettligt - für D185714.asm			
				3D 15.02.2013 kunze		DRAWING NAME: D185714 Draft Type Connection System.dft			
						PROJ. METHOD		SHEET	
								A4	
				PROD. DEV. GERMANY		DRAWING NUMBER		2 SHTS.	
				REPL. -		185714		REPL. BY -	
ALTERATIONS		DATE		NAME		AM			

CONNECTIONS

EXTRACTOR TUBE ET-W B

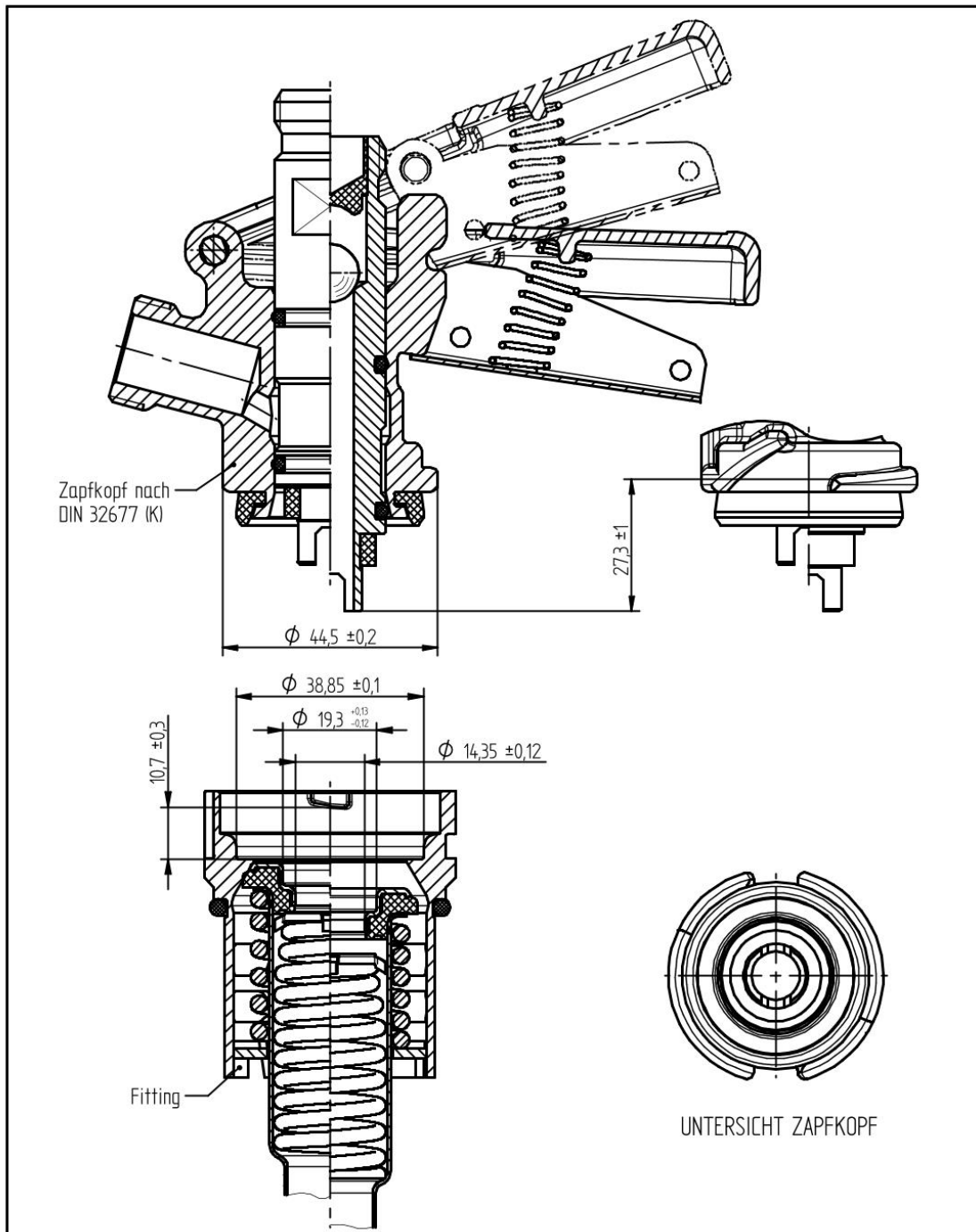

This drawing is the property of Dispense Systems International. The information on it is confidential, and must not be copied for any other purpose without the prior written permission of DSI Getränkearmaturen GmbH. If in doubt, please ask. Samples are required after each revision.

PRODUCT		TOLERANCES DIN ISO 2768-mH		LAST CHANGE		SCALE		WEIGHT VOLUME	
		ROUGHNESS DIN EN ISO 1302		- X Δ		MATERIAL			
		EDGES DIN EN ISO 13715		DATE		TITLE			
				DESIGN 19.02.2013 kunze		WB Verbindungssystem			
				AM 4427		FILE NAME: ET-W B bestellg für 194777.asm			
				2D 14.04.2020 kunze		DRAWING NAME: 910425 Connection System W B.dwg			
				3D 14.04.2020 kunze		PROJ. METHOD		SHEET	
						FORMAT A4		DRAWING NUMBER 910425	
				PROD. DEV. GERMANY		REPL. -		2	
ALTERATIONS		DATE		NAME		REPL. BY -		2 SHTS.	

DSI Micro Matic GmbH

Oberster Kamp 20
59069 Hamm
Germany
Telefon: +49 (0) 23 85 772 100
Fax: +49 (0) 23 85 772 249
dsi-sales@micro-matic.com
dsi.micro-matic.com

DSI SERVICE – TEAM

SALES AND CUSTOMER SERVICE:

Iryna Matyak
Eastern Europe, UK & Ireland
Telefon: +49 (0) 23 85 772 216
E-Mail: iryna.matyak@micro-matic.com

Debora Salvador
Western Europe & North-/ South-America
Telefon: +49 (0) 23 85 772 212
E-Mail: debora.salvador@micro-matic.com

Katja Spanke
Western Europe, Australia & Asia
Telefon: +49 (0) 23 85 772 215
E-Mail: katja.spanke@micro-matic.com

SALES FIELD SERVICE:

Rafael Kurzawa
D.A.CH.
Telefon: +49 2385 772 218
Mobil: +49 162 2892386
E-Mail: rafael.kurzawa@micro-matic.com